

APPENDIX for Workshop 1

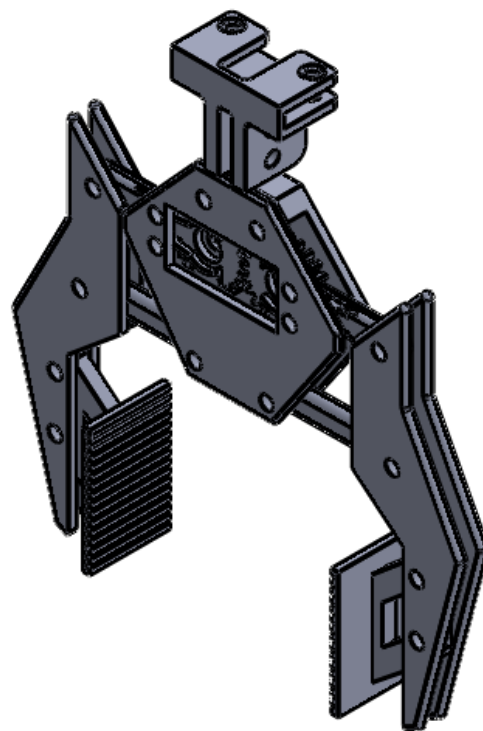
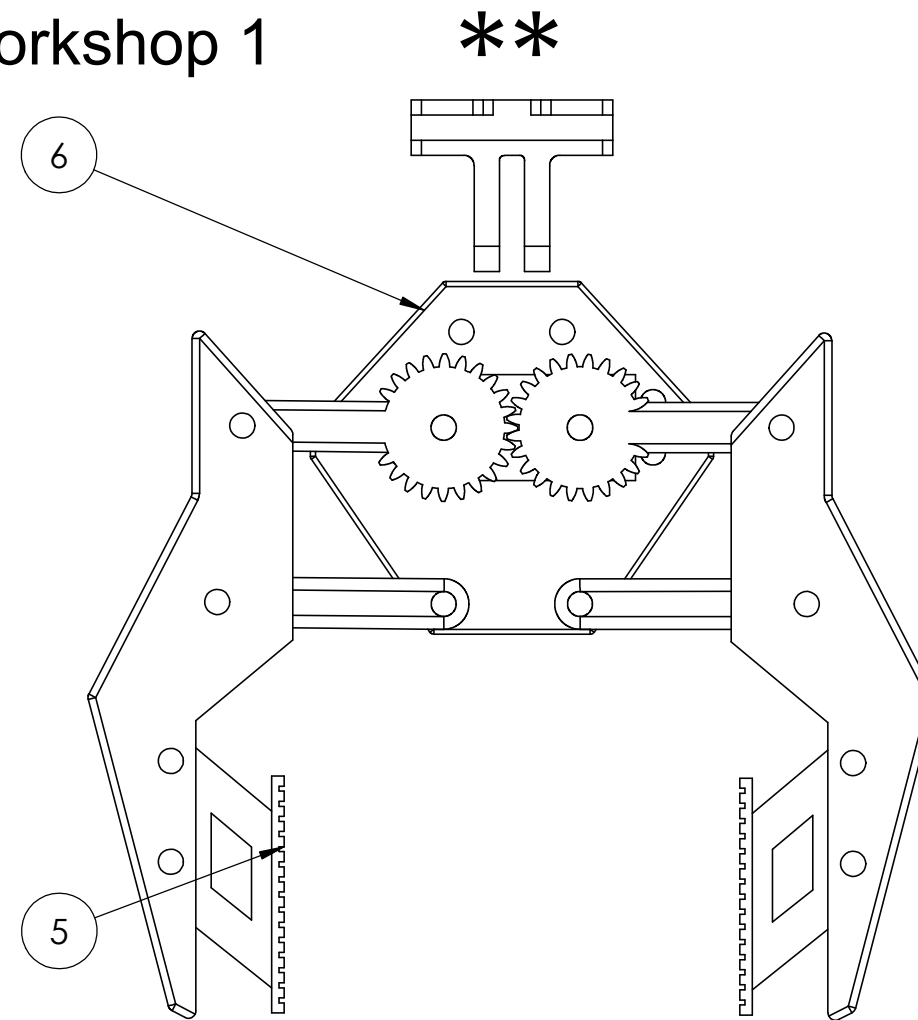
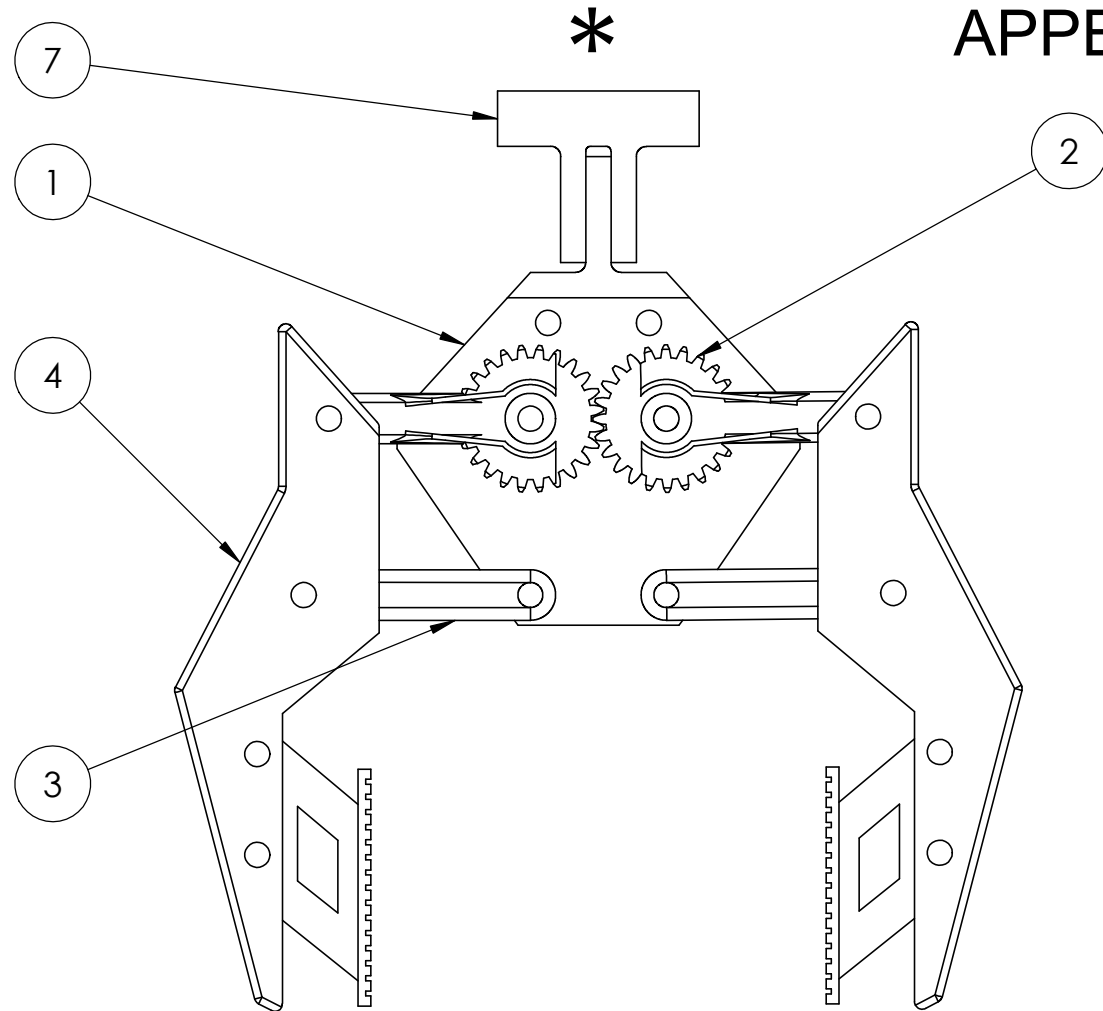

ITEM NO.	PART NUMBER	DESCRIPTION	QTY.
1	Base 1		1
2	Gear		2
3	Part3		2
4	Part4		4
5	Part5		2
6	Part2^Gripper		1
7	Part1^Gripper		1

UNLESS OTHERWISE SPECIFIED: DIMENSIONS ARE IN MILLIMETERS SURFACE FINISH: TOLERANCES: LINEAR: ANGULAR:		FINISH:	DEBURR AND BREAK SHARP EDGES		DO NOT SCALE DRAWING	REVISION
NAME	SIGNATURE	DATE			TITLE:	
DRAWN						
CHK'D						
APPV'D						
MFG						
Q.A			MATERIAL:	DWG NO.		A3
			WEIGHT:	SCALE:1:2	SHEET 1 OF 1	

* Item no. 6 was removed for better understanding
 ** Item no. 1 was removed for better understanding

Gripper

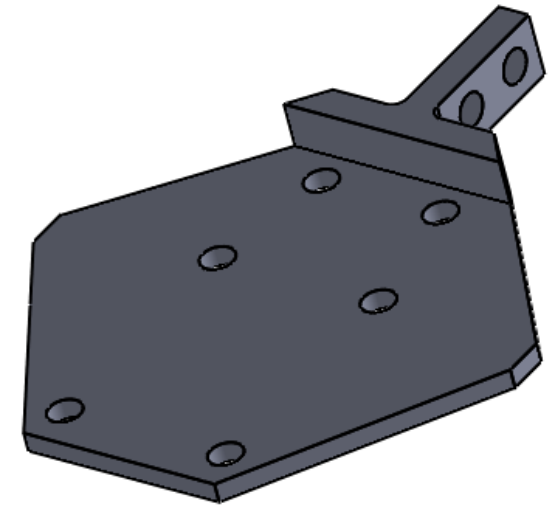
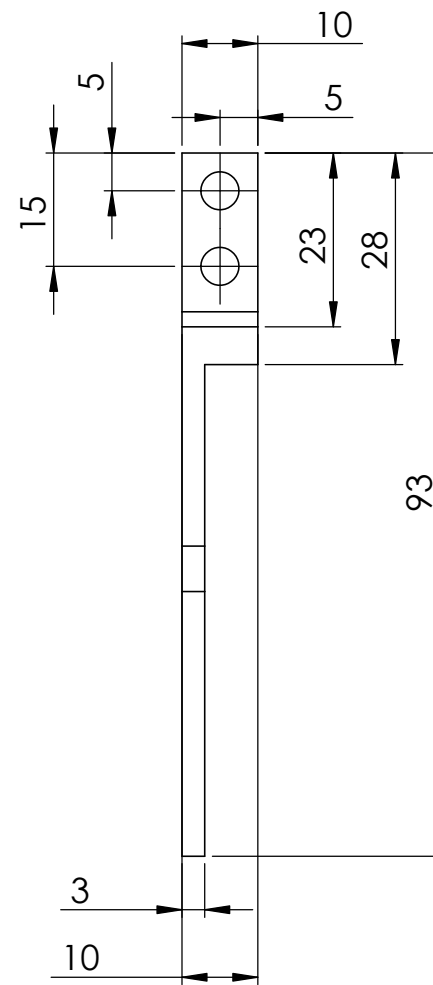
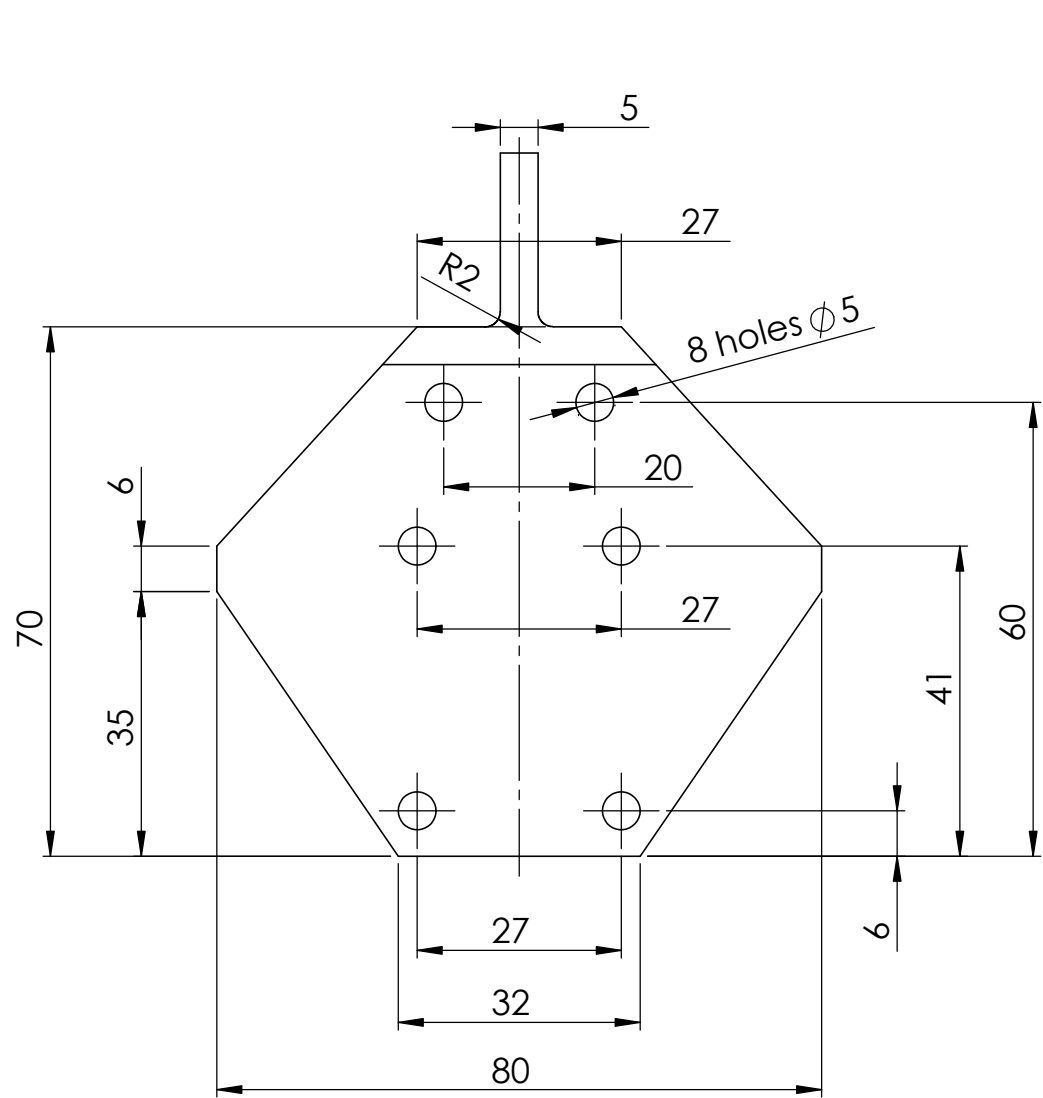

UNLESS OTHERWISE SPECIFIED: DIMENSIONS ARE IN MILLIMETERS SURFACE FINISH: TOLERANCES: LINEAR: ANGULAR:				FINISH:		DEBURR AND BREAK SHARP EDGES		DO NOT SCALE DRAWING		REVISION	
DRAWN				SIGNATURE		DATE		TITLE:			
CHK'D											
APPV'D											
MFG											
Q.A								MATERIAL:		DWG NO.	
										Base 1	
								WEIGHT:		A3	
								SCALE:1:1		SHEET 1 OF 1	

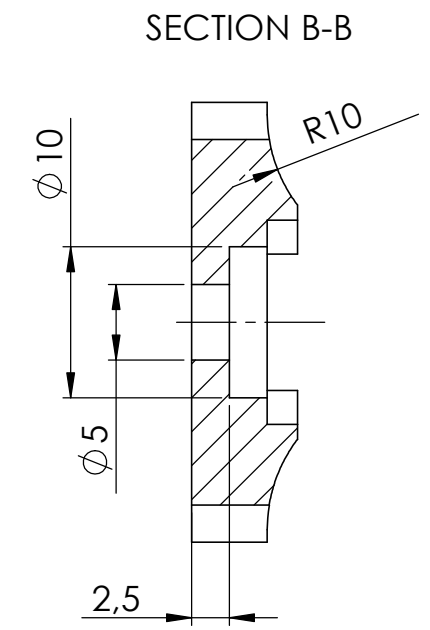
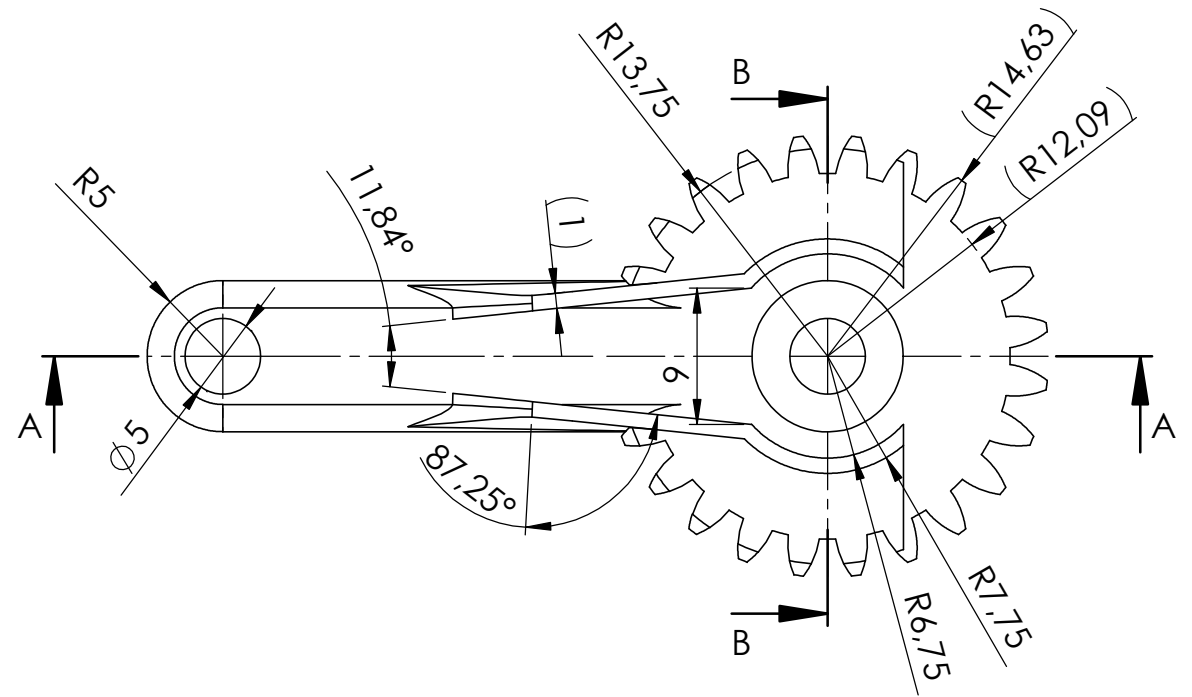
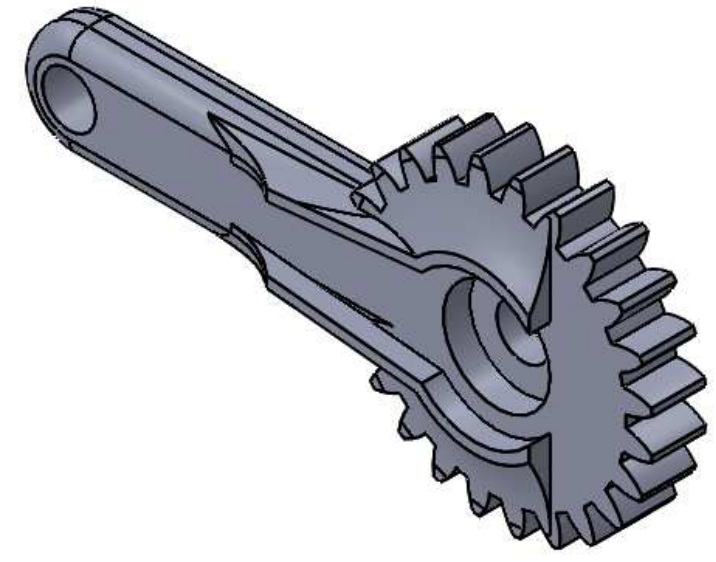
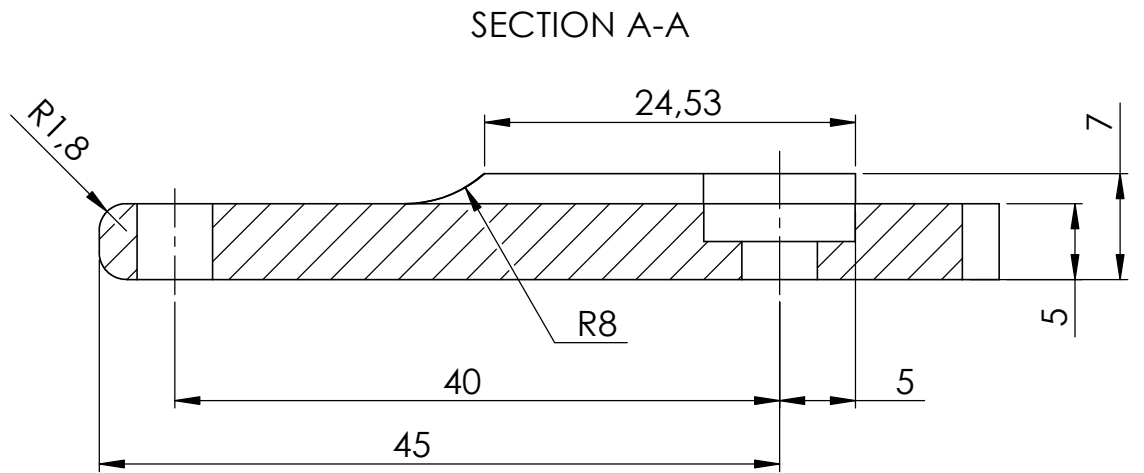

$z = 24$
 $m = 1.125$
 $a = 14.5$

UNLESS OTHERWISE SPECIFIED: DIMENSIONS ARE IN MILLIMETERS SURFACE FINISH: TOLERANCES: LINEAR: ANGULAR:				FINISH:		DEBURR AND BREAK SHARP EDGES		DO NOT SCALE DRAWING		REVISION	
DRAWN				NAME		SIGNATURE		DATE		TITLE:	
CHK'D											
APPV'D											
MFG											
Q.A								MATERIAL:		DWG NO.	
										A3	
								WEIGHT:		SCALE:1:1	
										SHEET 1 OF 1	

Gear

4 3 2 1

F

F

SECTION A-A

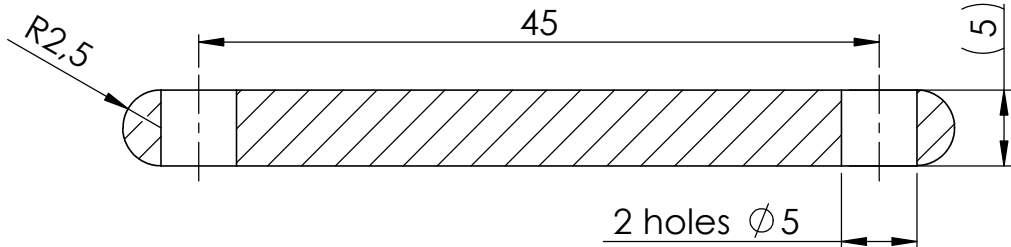

E

E

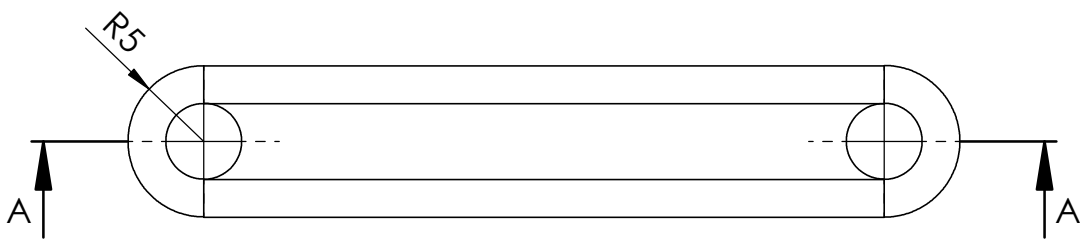

D

D

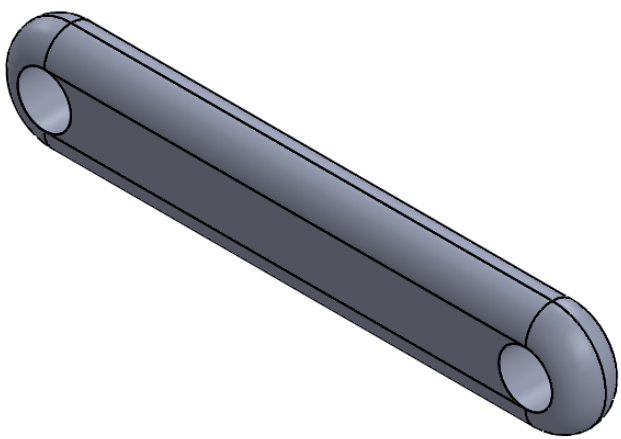

C

C

B

B

UNLESS OTHERWISE SPECIFIED: DIMENSIONS ARE IN MILLIMETERS SURFACE FINISH: TOLERANCES: LINEAR: ANGULAR:	FINISH:		DEBURR AND BREAK SHARP EDGES		DO NOT SCALE DRAWING	REVISION

	NAME	SIGNATURE	DATE		TITLE:
DRAWN					
CHK'D					
APPV'D					
MFG					

Q.A				MATERIAL:	DWG NO.	Part3	A4
				WEIGHT:	SCALE:1:1	SHEET 1 OF 1	

A

A

4 3 2 1

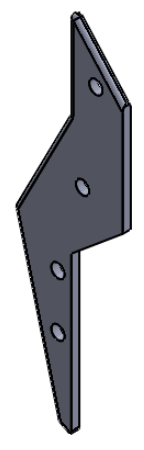
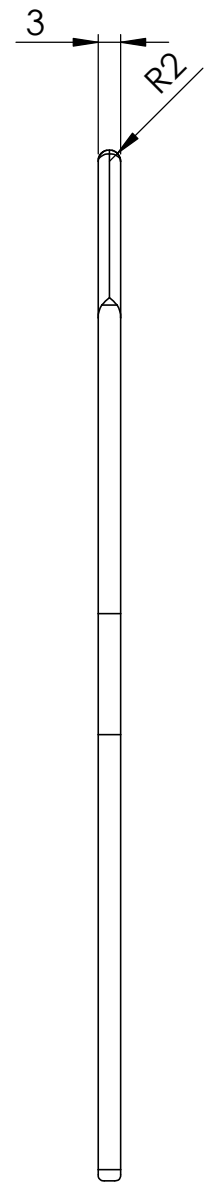
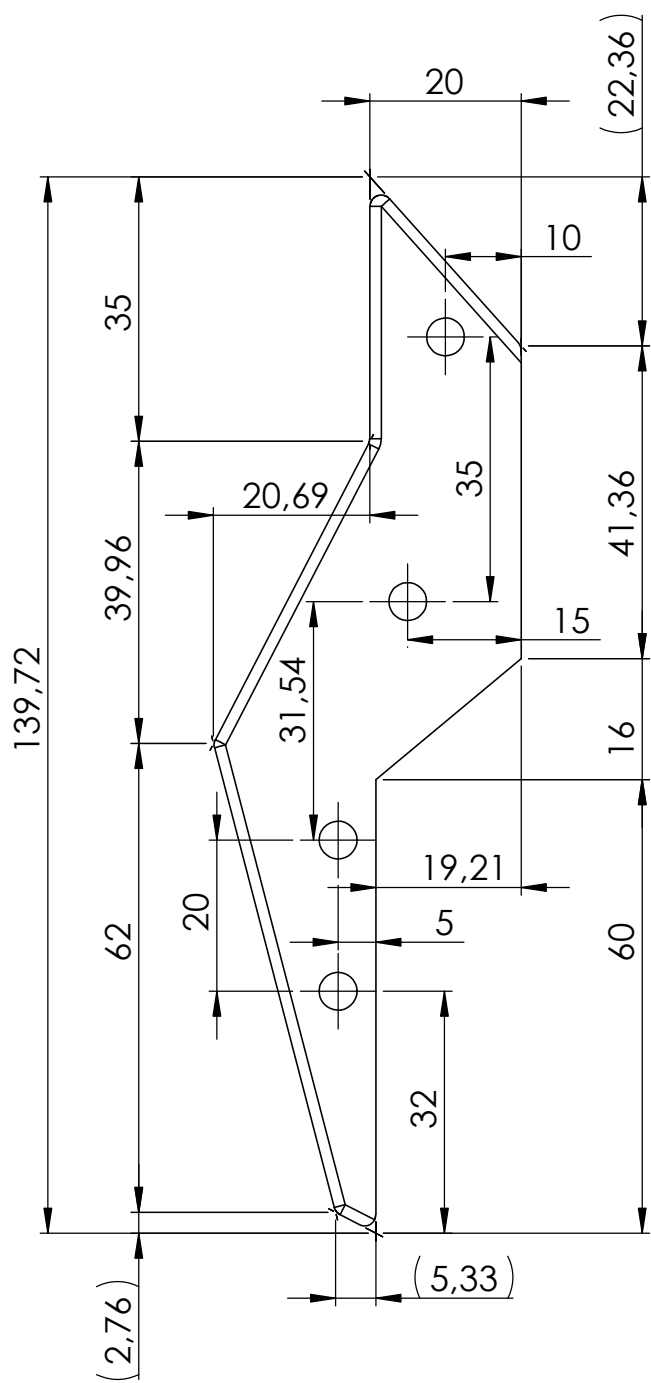

UNLESS OTHERWISE SPECIFIED: DIMENSIONS ARE IN MILLIMETERS SURFACE FINISH: TOLERANCES: LINEAR: ANGULAR:				FINISH:		DEBURR AND BREAK SHARP EDGES		DO NOT SCALE DRAWING		REVISION	
DRAWN				SIGNATURE		DATE		TITLE:			
CHK'D											
APPV'D											
MFG											
Q.A						MATERIAL:		DWG NO.		A4	
								Part4			
						WEIGHT:		SCALE: 1:1		SHEET 1 OF 1	

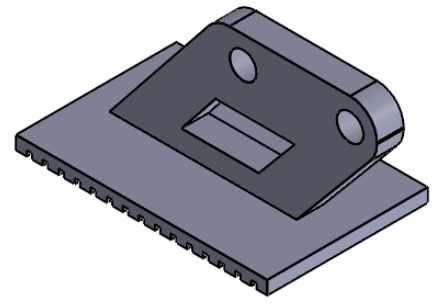
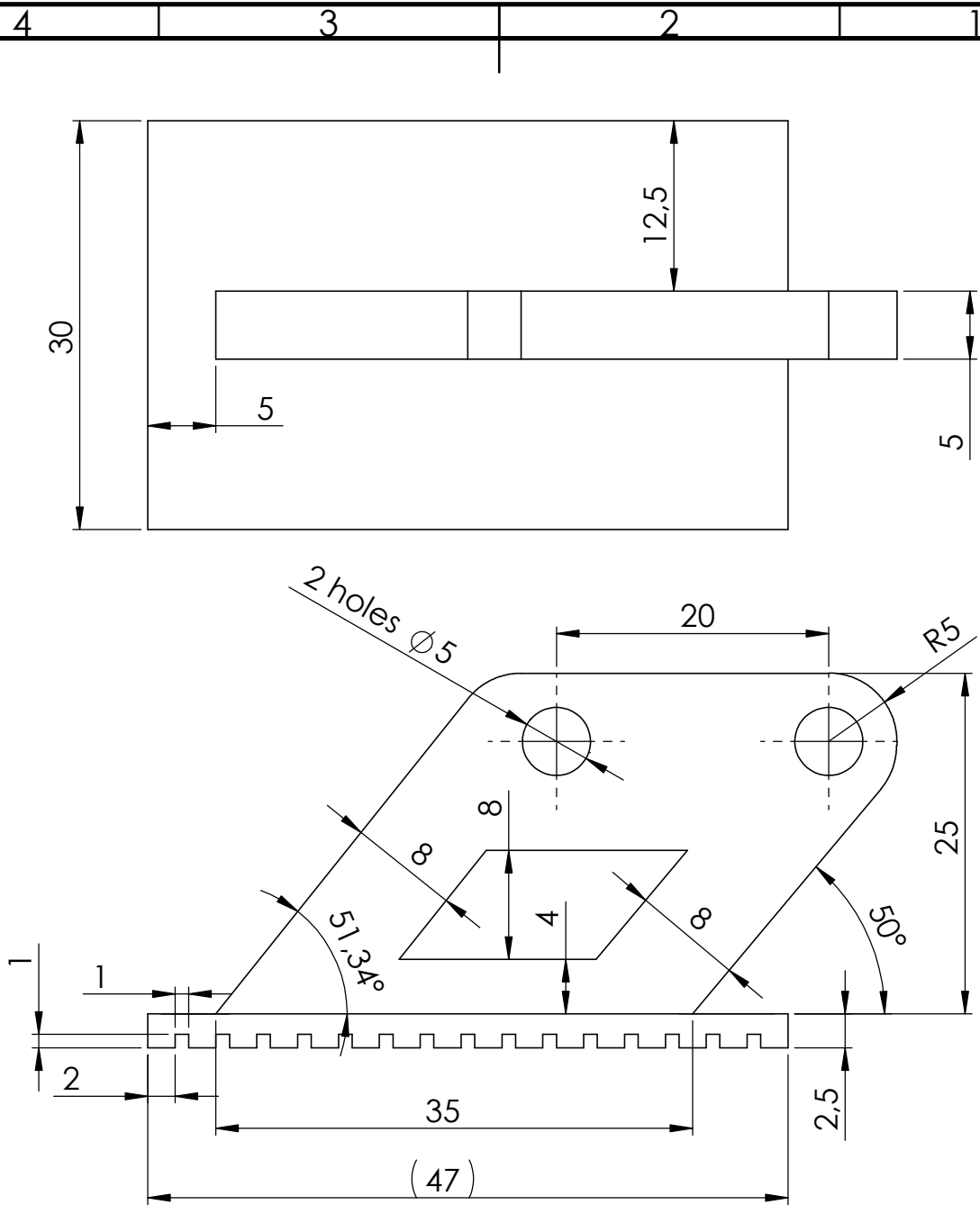

UNLESS OTHERWISE SPECIFIED:
 DIMENSIONS ARE IN MILLIMETERS
 SURFACE FINISH:
 TOLERANCES:
 LINEAR:
 ANGULAR:

FINISH:

DEBURR AND
 BREAK SHARP
 EDGES

DO NOT SCALE DRAWING

REVISION

NAME	SIGNATURE	DATE
DRAWN		
CHK'D		
APPV'D		
MFG		
Q.A		

TITLE:

MATERIAL:

DWG NO. **Part5**

A4

WEIGHT:

SCALE:1:1

SHEET 1 OF 1

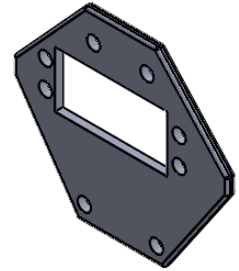
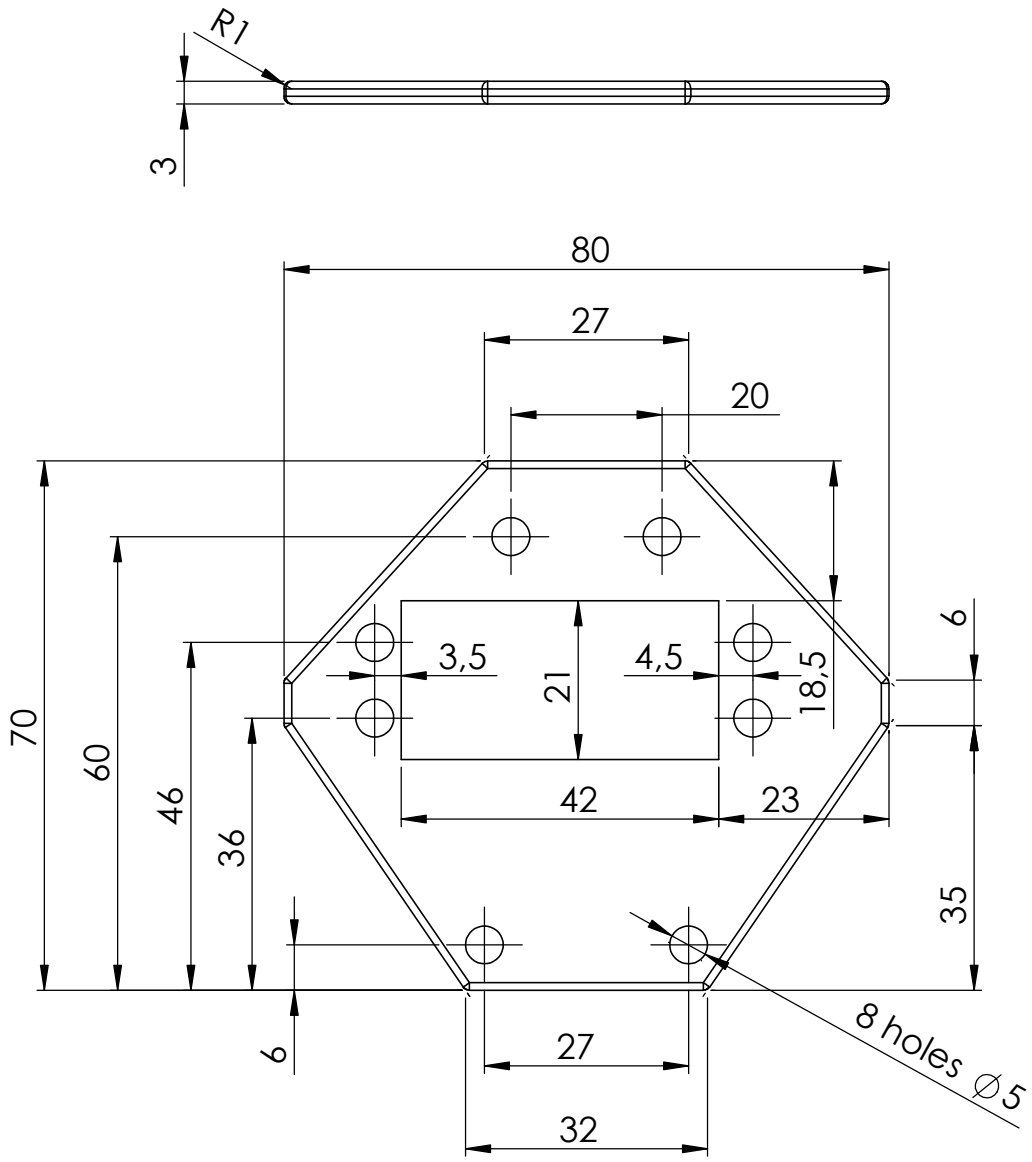

UNLESS OTHERWISE SPECIFIED:
 DIMENSIONS ARE IN MILLIMETERS
 SURFACE FINISH:
 TOLERANCES:
 LINEAR:
 ANGULAR:

FINISH:

DEBURR AND
 BREAK SHARP
 EDGES

DO NOT SCALE DRAWING

REVISION

NAME	SIGNATURE	DATE
DRAWN		
CHK'D		
APPV'D		
MFG		
Q.A		

TITLE:

MATERIAL:

DWG NO.
Part2-Gripper

A4

WEIGHT:

SCALE: 1:1

SHEET 1 OF 1

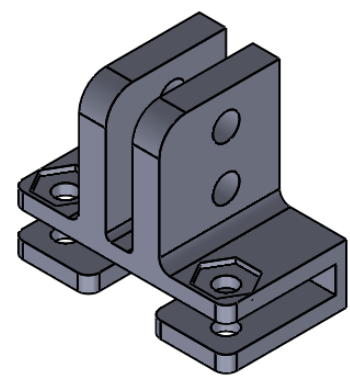
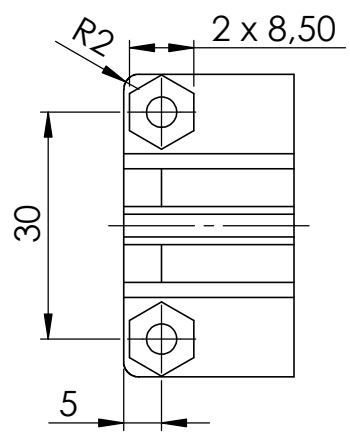
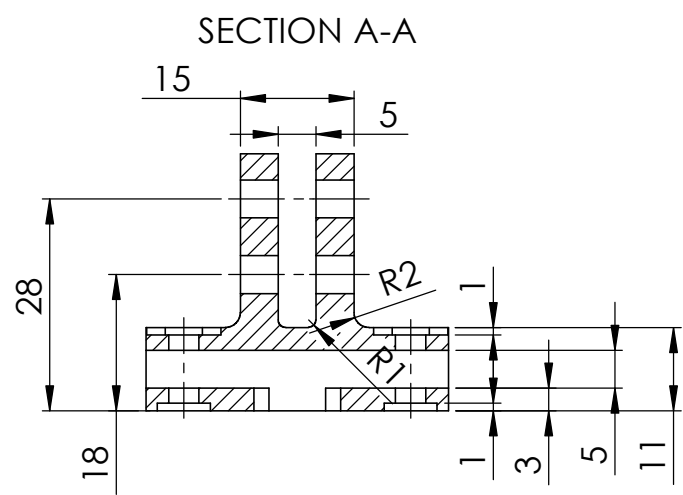
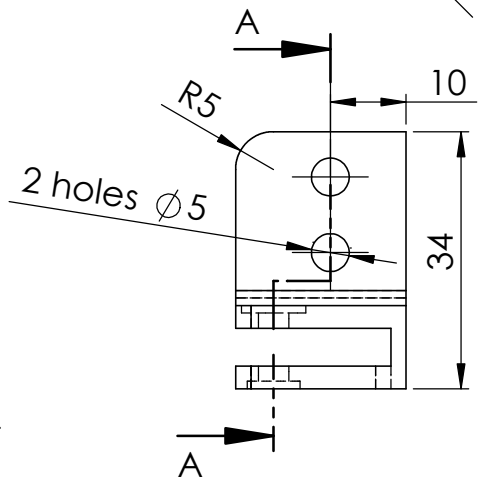
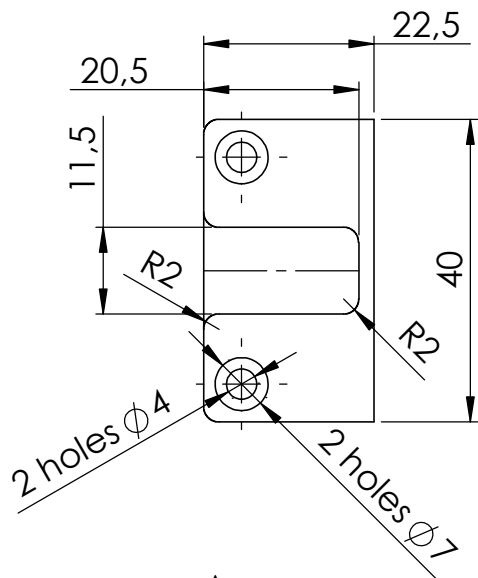

UNLESS OTHERWISE SPECIFIED: DIMENSIONS ARE IN MILLIMETERS SURFACE FINISH: TOLERANCES: LINEAR: ANGULAR:			FINISH:		DEBURR AND BREAK SHARP EDGES		DO NOT SCALE DRAWING		REVISION		
DRAWN			SIGNATURE		DATE		TITLE:				
CHK'D							DWG NO. <h1>Part 1-Gripper</h1>				
APPV'D											
MFG											
Q.A											
					MATERIAL:		SCALE: 1:1		SHEET 1 OF 1		
					WEIGHT:				A4		